



# FOPPAEDRETTI®

design *Ufficio Tecnico*

**Benchef**



Made in Italy

Istruzione montaggio e uso

Instructions for assembly and use

Instructions de montage et mode d'emploi

Montage- und Gebrauchsanweisung

Instrucciones de montaje y uso

Aanwijzingen voor de montage en het gebruik

Carrello in legno porta microonde

Wood microwave cart

Chariot en bois porte micro-ondes

Holzwagen für die Mikrowelle

Carro de madera porta microondas

Houten wagentje voor magnetron

**Avvertenze**

Warning

Avvertissement

Warnung

Advertencias

Waarschuwingen

**I Leggere attentamente e conservare per future referenze**

- Accertarsi del corretto montaggio prima del suo impiego.
- Controllare periodicamente il perfetto bloccaggio di tutti i componenti.
- Pulire con un panno umido o del detergente neutro (no solventi) e asciugare accuratamente.

**GB Read the instructions carefully and keep for future reference**

- Make sure of proper assembly before using.
- Check the proper locking of all components regularly.
- Clean with a damp cloth or with neutral detergent (not solvents) and dry carefully.

**F Lire attentivement et conserve en cas de besoin**

- Assurez-vous que le montage est correct avant l'utilisation.
- Contrôler périodiquement que tous les éléments sont parfaitement bloqués.
- Nettoyer avec un chiffon humide et du détergent neutre (nonsolvants), essuyer soigneusement.

**D Aufmerksam lesen und für zukünftige Referenzen aufbewahren**

- Versichern Sie sich vor dem Einsatz der korrekten Montage.
- Kontrollieren Sie regelmäßig das perfekte Einrasten aller Einzelteile.
- Reinigen Sie den Artikel mit einem feuchten Tuch oder mit einem neutralen Reinigungsmittel (keine Lösungsmittel) und trocknen Sie ihn akkurat ab.

**E Leer atentamente y conservar para futuras referencias**

- Comprobar el montaje correcto antes de su uso.
- Controlar periódicamente el bloqueo perfecto de todos los componentes.
- Limpiar con un paño húmedo o con detergente neutro (no con solventes) y secar cuidadosamente

**NL Lees deze aanwijzingen met aandacht en bewaar ze voor gebruik later**

- Controleer de correcte montage vóór het gebruik.
- Controleer regelmatig de correcte blokkering van alle onderdelen.
- Schoonmaken met een vochtige doek of met een neutraal reinigingsmiddel (geen oplosmiddelen) en zorgvuldig droogwrijven.

**Minuteria**

Component parts

Composition

Zusammensetzung

Composición

Konstruktie



ax4



bx16



cx4



dx2



ex6



fx6

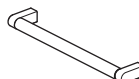

gx2



h



i



l

**Componenti**

Component parts

Composition

Zusammensetzung

Composición

Konstruktie

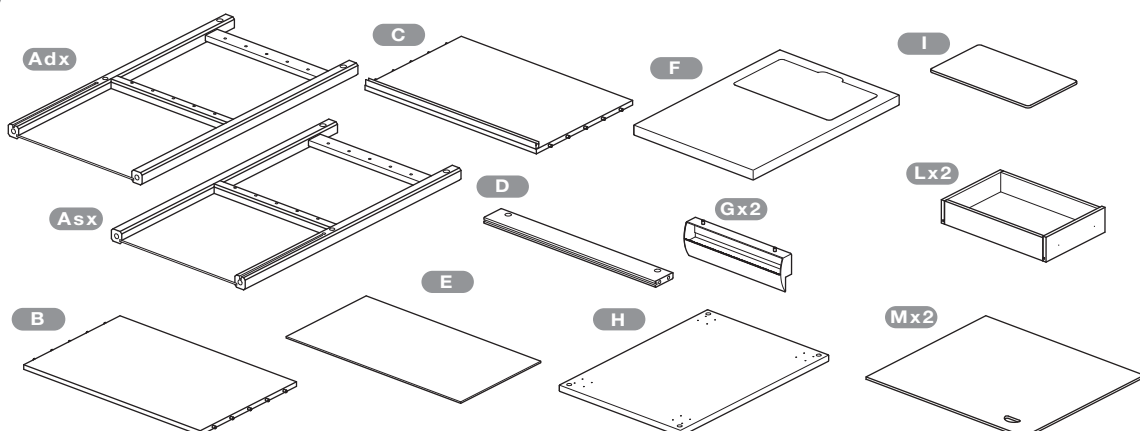

1

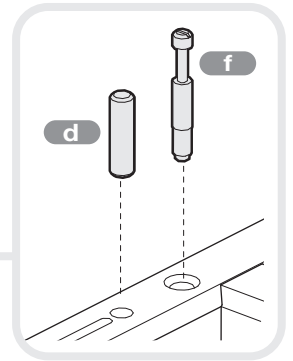
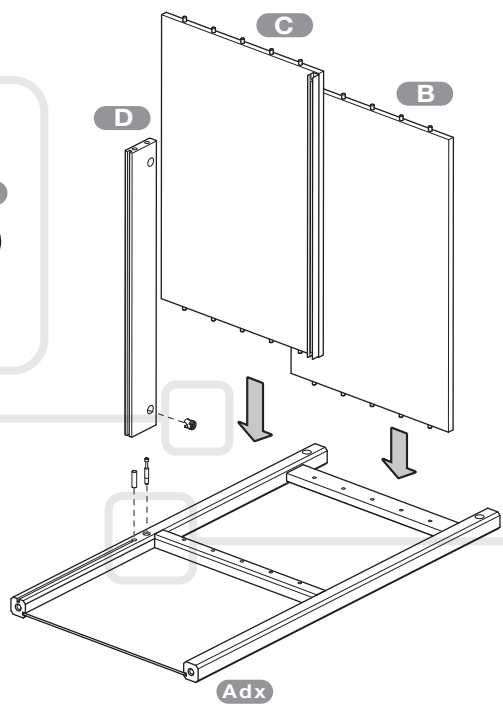
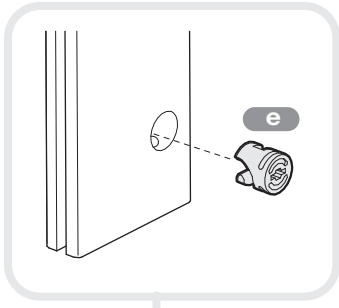

2

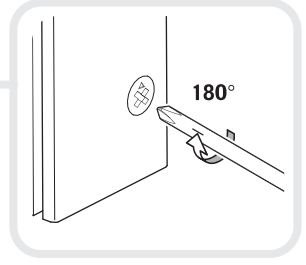
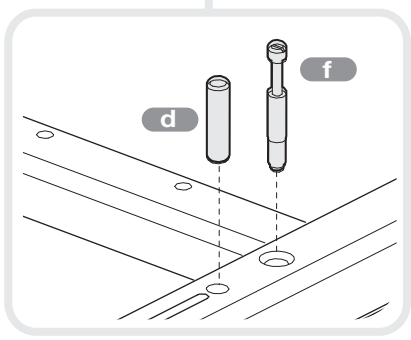
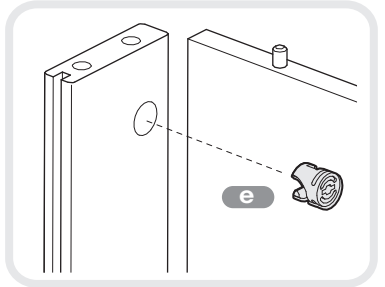
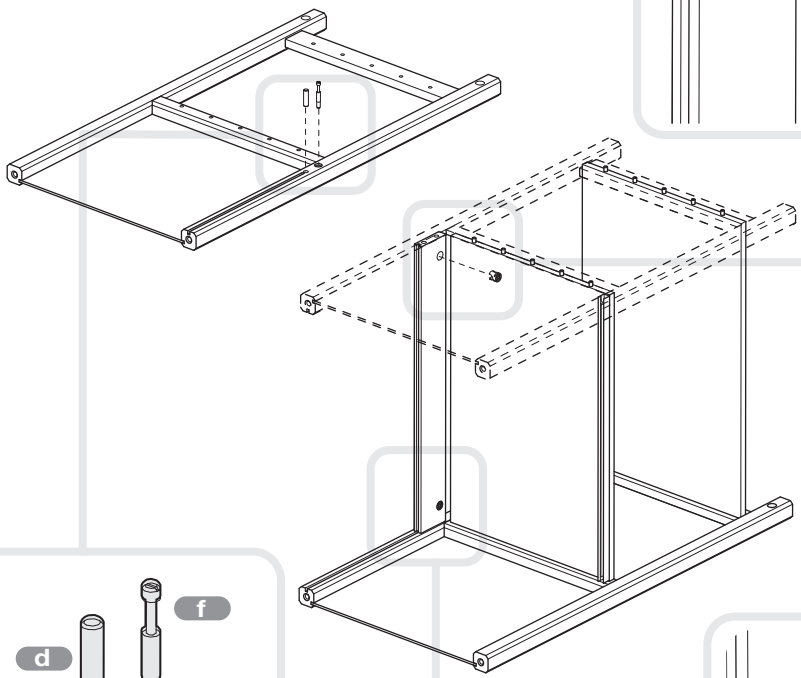

3

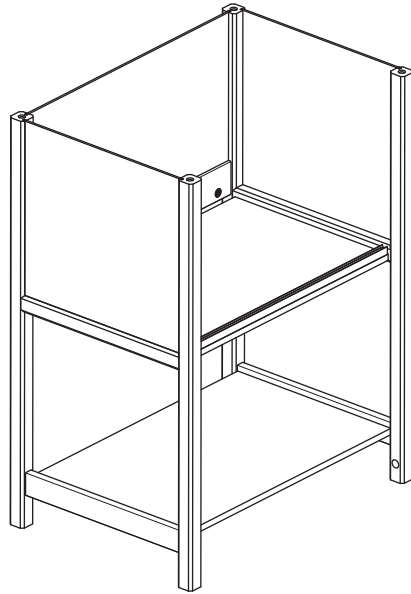
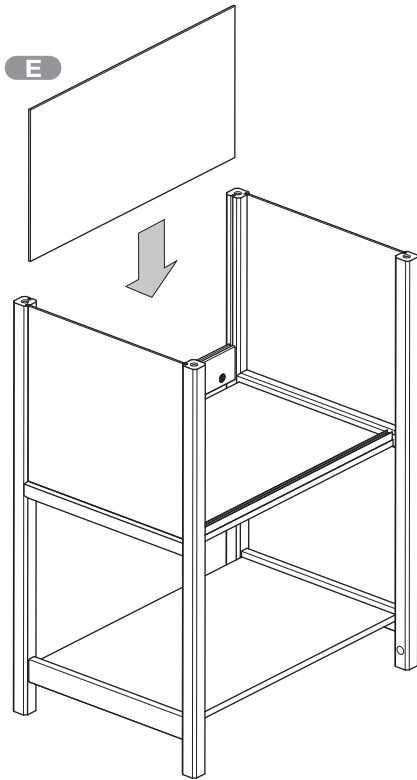

4

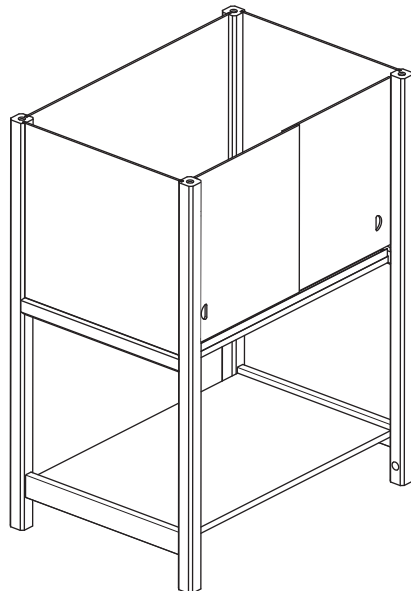
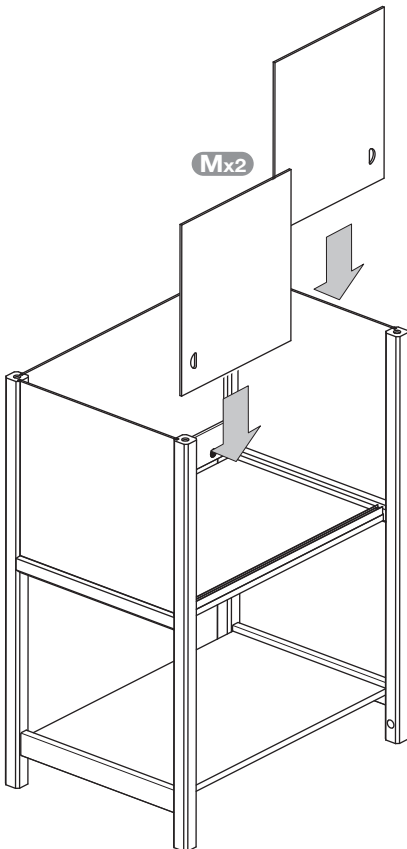

5

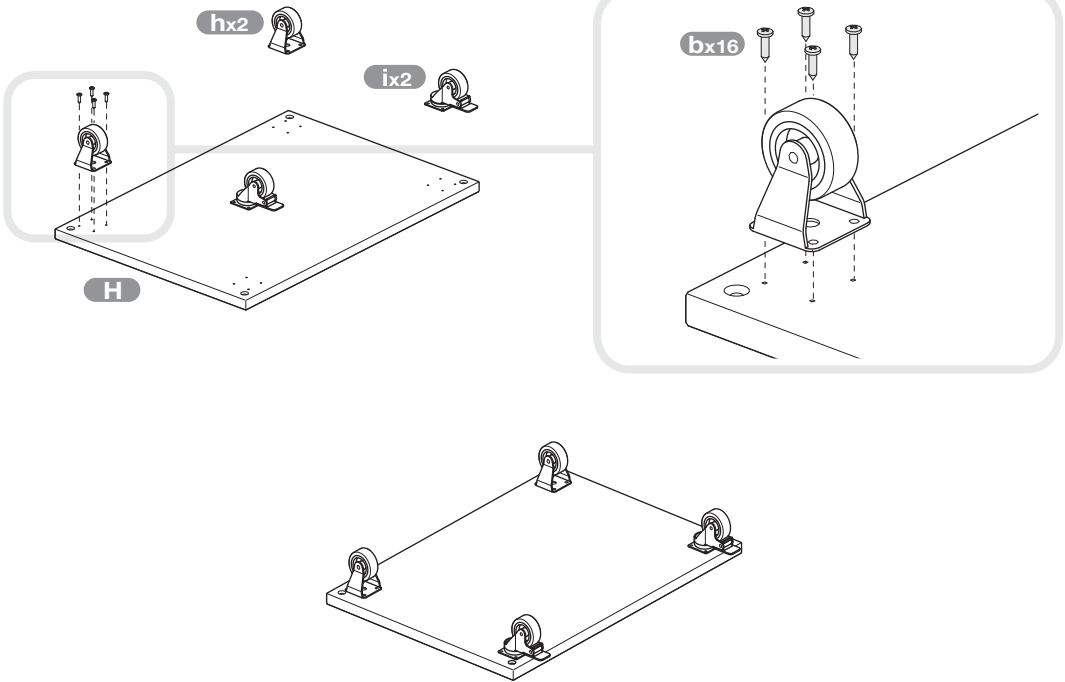

6

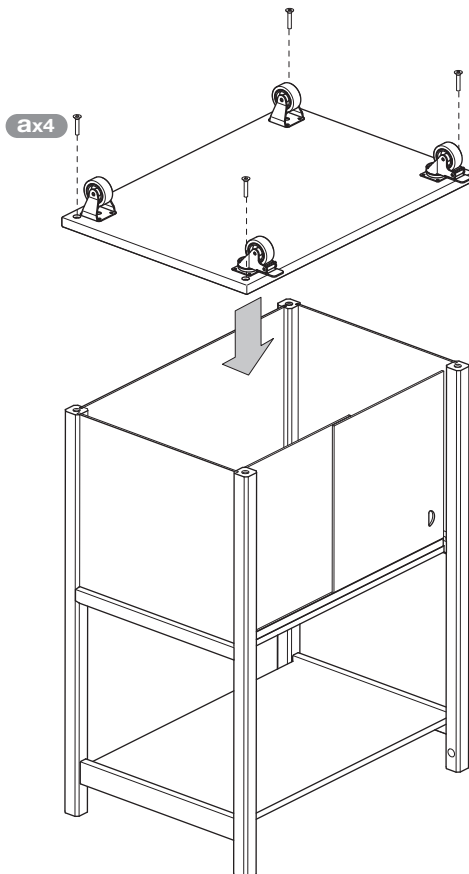

7

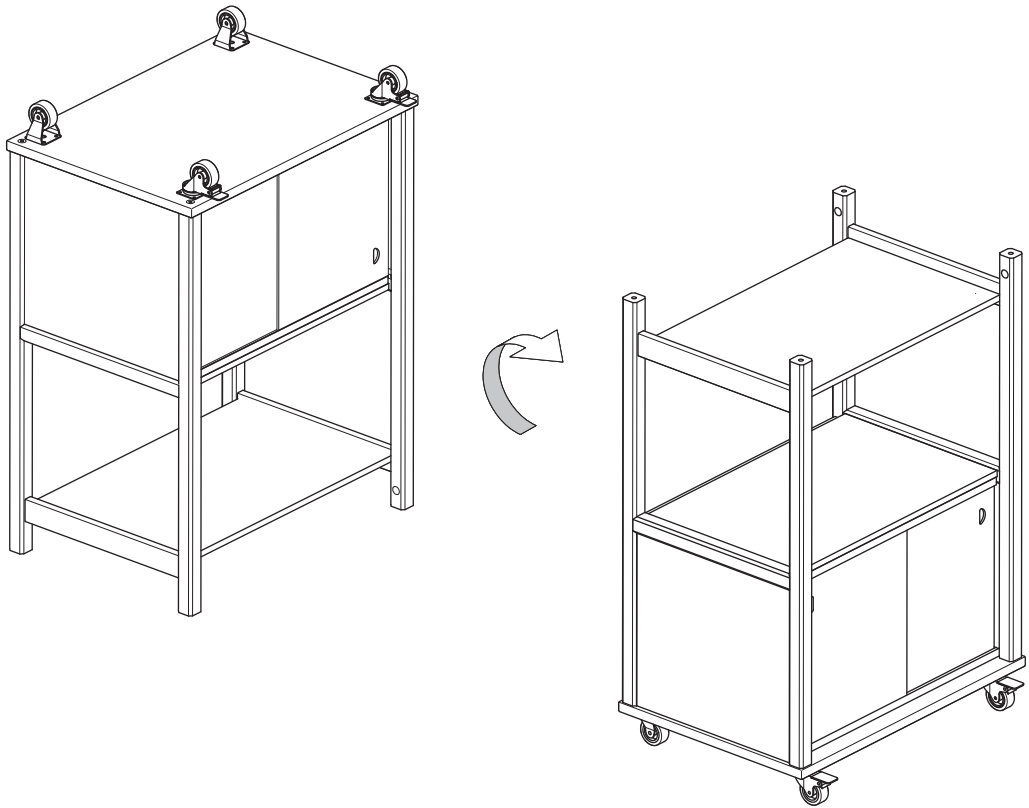

8

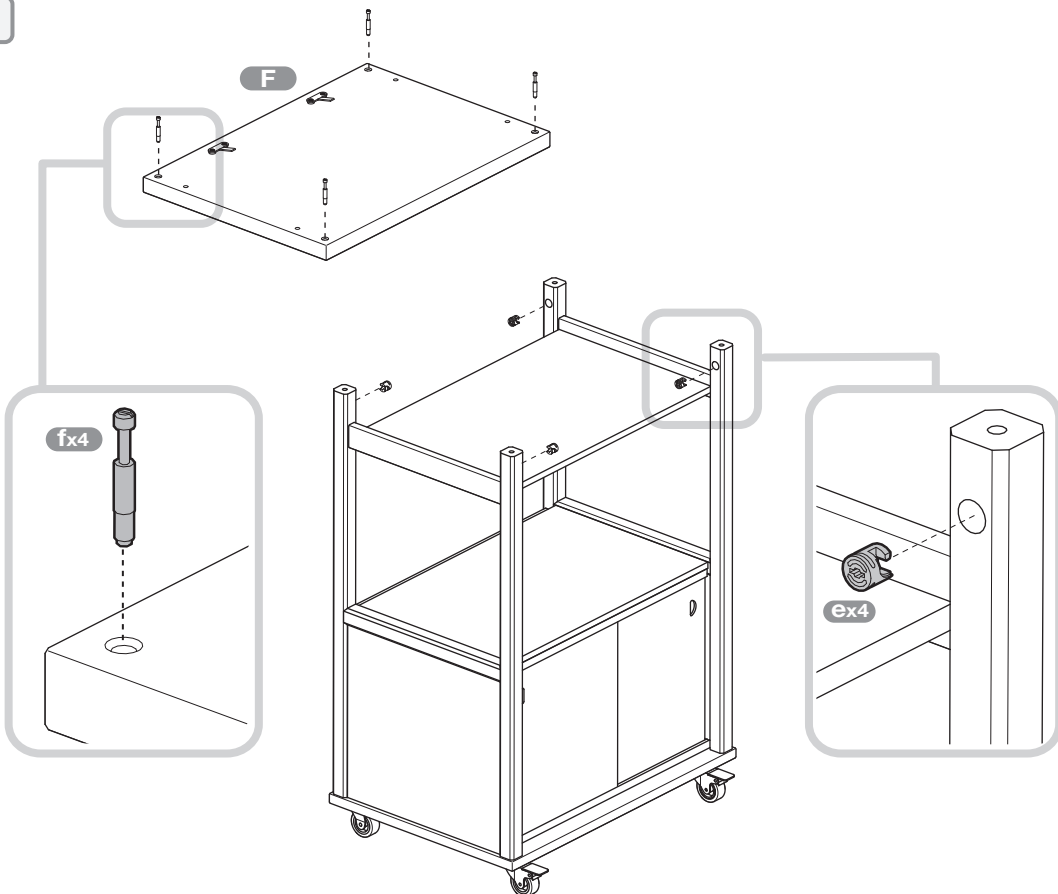

9

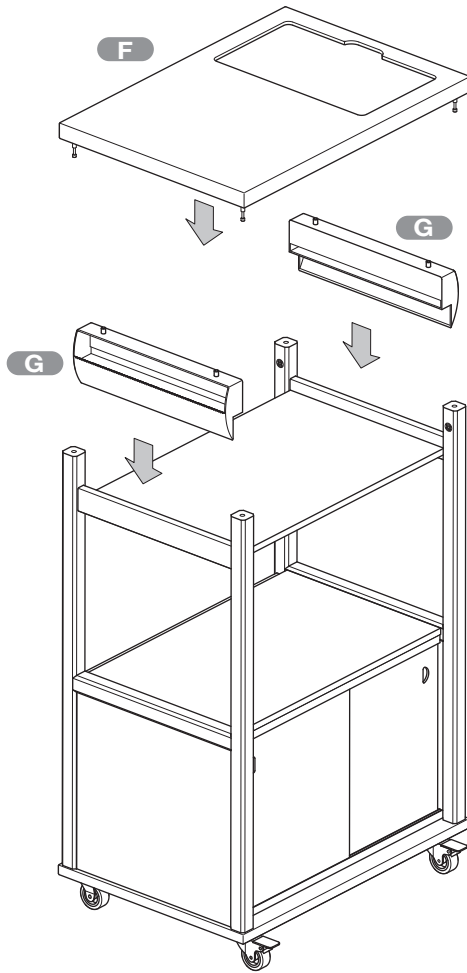

10 x2

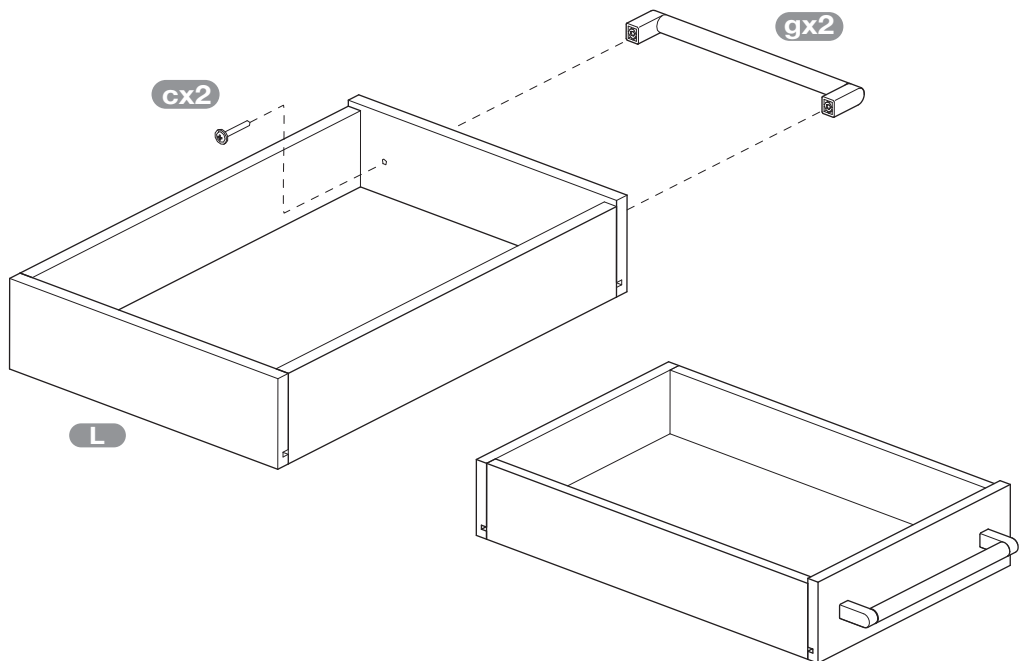

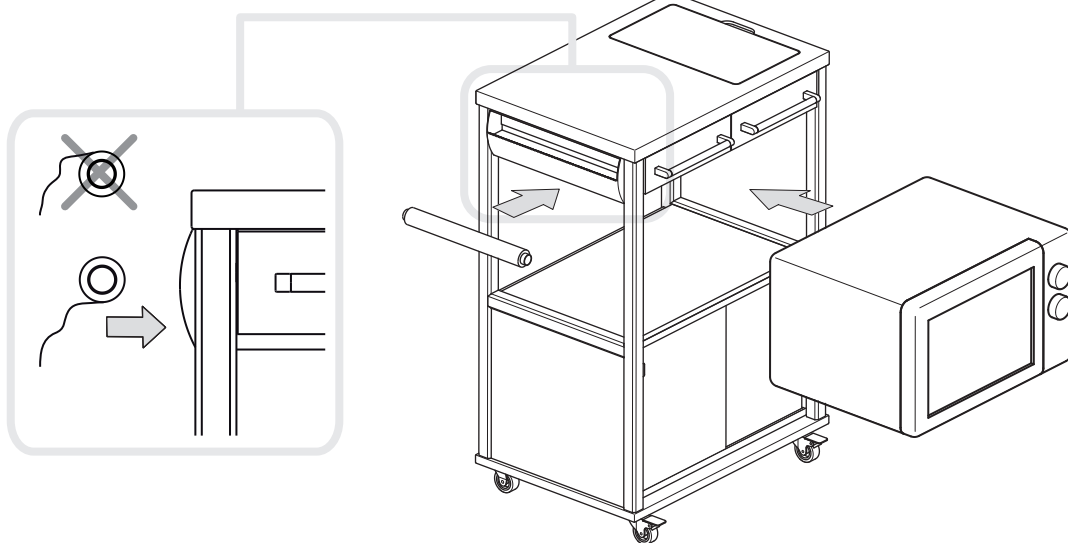
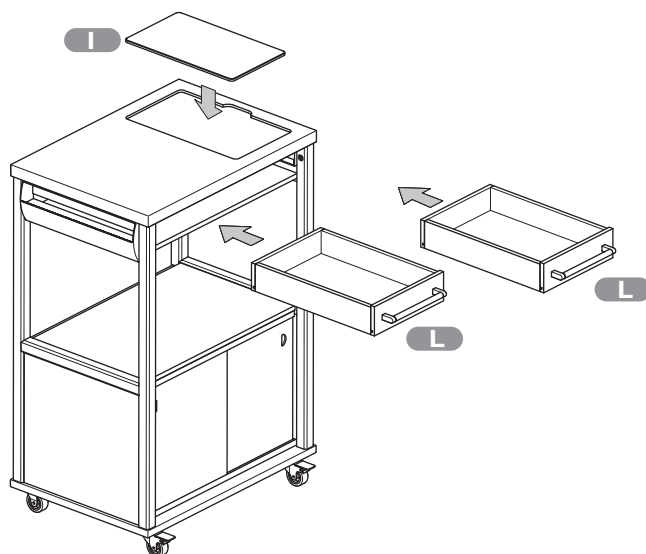

- I**
- Struttura in legno di faggio.
  - Piano superiore in listellare di faggio.
  - Piani in truciolare nobilitato.
  - Fianchi e schienale in MDF.
  - Tagliere in PEHD.
  - Porta rotolo in ABS.
  - Ruote in gomma con struttura in ferro zincato.
  - Antine in plexiglas.

- GB**
- Coated beechwood frame.
  - Upper top made of beech blockboard.
  - Chipboard table tops covered in melamine.
  - MDF sides and backrest.
  - PEHD chopping board.
  - Roll holder made of ABS.
  - Rubber wheels with galvanized iron frame
  - Plexiglas doors.

- F**
- Structure en bois de hêtre vernis.
  - Plateau supérieur en hêtre lamellé.
  - Plan en particules revêtues mélamine.
  - Côtés et dos en MDF.
  - Planche à découper en PEHD.
  - Porte-rouleaux en ABS.
  - Roulette en caoutchouc avec structure en fer zingué.
  - Portes en plexiglas.

- D**
- Aufbau aus lackiertem Buchenholz.
  - Obere Ebene aus Buche-Stäbchenplatte
  - Flächen aus Spanplatte mit Melaminüberzug.
  - Seitenteile und Rückwand aus MDF.
  - Schneidebrett aus PEHD.
  - Papierrollenhalter aus ABS.
  - Räder aus Gummi mit Rahmen aus verzinktem Eisen.
  - Flügel aus Plexiglas.

- E**
- Estructura de madera de haya barnizada.
  - Plano superior de entablillado de haya.
  - Planos de aglomerado recubierto con melamina.
  - Costados y respaldo de MDF.
  - Tabla de picar de PEHD
  - Porta rollo de ABS.
  - Ruedas de goma con estructura de hierro galvanizado.
  - Puertas de plexiglas.

- NL**
- Konstruktie van gelakt beukehout.
  - Bovenvlak in atten beukenhout.
  - Tafelbladen van spaanplaat met melamine fineerlaag.
  - Zijkanten en rugleuning in MDF.
  - Hakbord in PEHD.
  - Rolhouder in ABS.
  - Rubberen wielen met structuur in verzinkt ijzer.
  - Deurtjes in plexiglas.

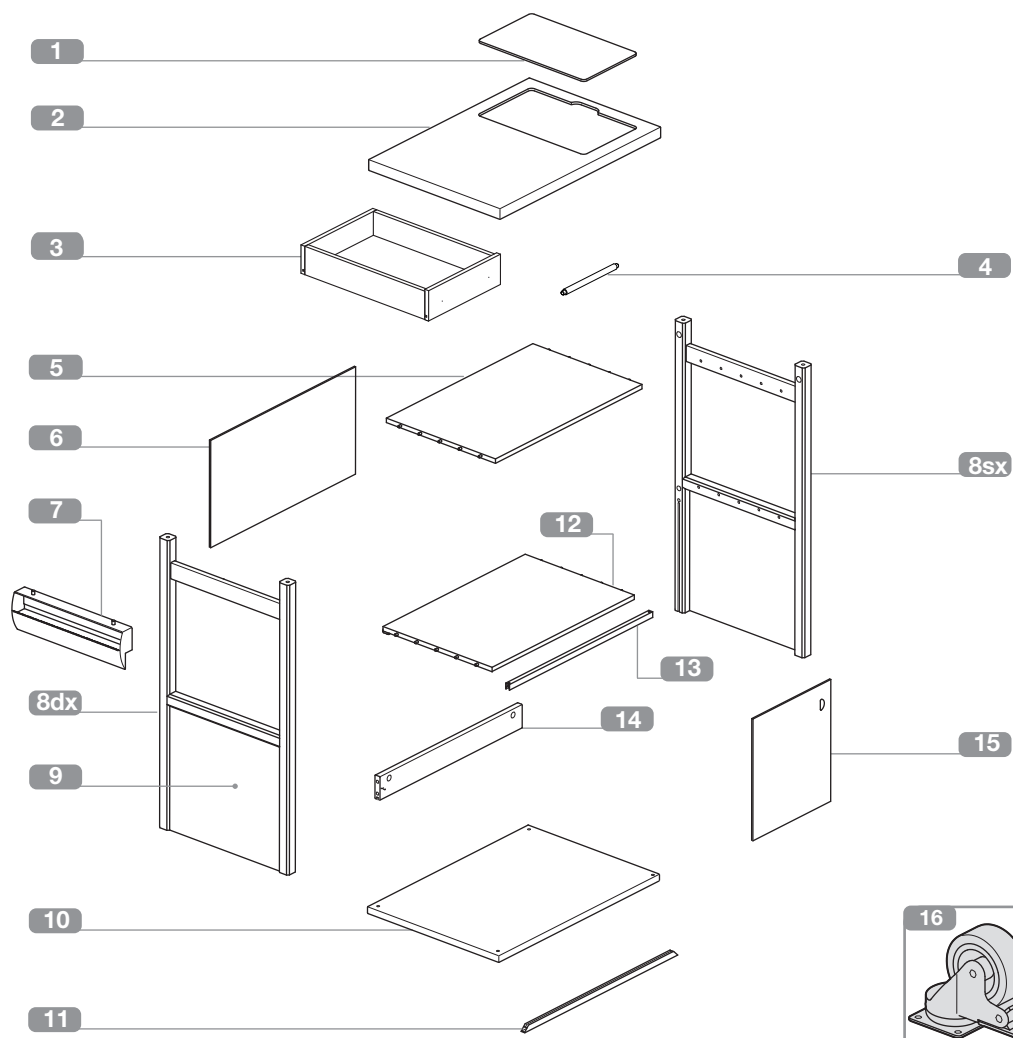

1	cod.0049240510	8dx	cod.00904053 ..	14	cod.00904052 ..
2	cod.00904050 ..	8sx	cod.00904054 ..	15	cod.0049504200
3	cod.00281021 ..	9	cod.70497066 ..	16	cod.0049221319
4	cod.00904051 ..	10	cod.00272265 ..	17	cod.0049221119
5	cod.00272264 ..	11	cod.3032507100	18	cod.0040063200
6	cod.70497067 ..	12	cod.00272263 ..	19	cod.0044729536
7	cod.0044729000	13	cod.3032507400	20	cod.7010164600

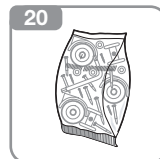
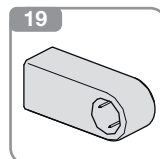
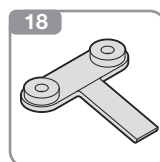
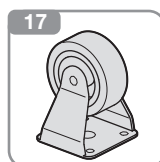
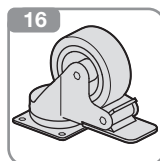

**I** Ogni codice ricambio deve essere sempre composto da dieci cifre: completare gli eventuali codici da otto cifre con le due indicanti il colore.

**Attenzione:** le sostituzioni devono essere richieste solamente tramite il rivenditore.

**GB** Every code reciprocation always must be composed from ten figures: to complete the eventual codes from eight indicating figures with the two color.

**Note:** the replacement parts may only be ordered through the retailer.

**F** Chaque code je rends doit être toujours composé de dix chiffres : compléter les eventuels codes de huit chiffres avec deux heures indiquant la couleur.

**Attention:** les substitutions ne peuvent être effectuées que par l'intermédiaire du revendeur.

**D** Jeder Code gebe ich zurück muß mich immer aus zehn Zahlen zusammensetzen: die möglichen Codes von acht Zahlen mit zwei Stunden zu vervollständigen, die die Farbe angeben.

**Wichtig:** ersatz darf nur über den Händler angefordert werden.

**E** Cada código vuelvo debo siempre ser compuesto de diez cifras: completar los posibles códigos de ocho cifras con las dos horas que indican el color.

**¡Atención!** las sustituciones deben ser solicitadas solamente a través del revendedor.

**NL** Elke code geef ik moet altijd uit tien cijfers samengesteld zijn terug: de eventuele codes van acht cijfers met twee uur aanvullen dat de kleur aangeeft.

**Opgelet:** vervangingen dienen uitsluitend via de wederverkoper te worden besteld.

Naturale	03
Noce	06
Bianco	10
Bianco/Naturale	30
Wengè	86

**FOPPAPEDRETTI**  
 Foppa Pedretti S.p.A. Via A. Volta, 11  
 24064 - Grumello del Monte, Bergamo - Italy  
 tel +39 035.830.497 fax +39 035.831.283  
 www.foppapedretti.it