

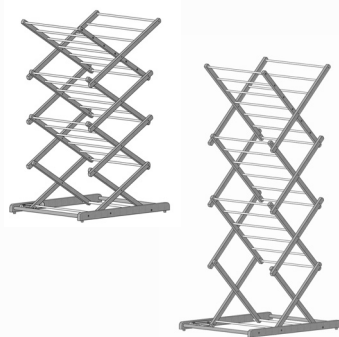

FOPPAEDRETTI®

design Ufficio Tecnico

Stendipiù



Made in Italy

Istruzioni di montaggio
 Assembly instructions
 Notice d'emploi
 Montageanleitung
 Instrucciones de montaje
 Montage instukties

Stendibiancheria pieghevole estendibile
 Folding and extending airer
 Séchoir à linge pliant, étirable
 Zusammenklappbarer, ausziehbarer wäscheständer
 Tendadero plegable, extensible
 Opvouowbaar en uitrekbaar droogrek

Avvertenze

Warning

Avvertissement

Warnung

Advertencias

Waarschuwingen

I Leggere attentamente e conservare per future referenze

- Verificate la perfetta apertura prima di utilizzare **Stendipiù**.
- Controllate periodicamente il perfetto bloccaggio delle viti.
- Pulire con un panno umido o con detergente neutro (no solventi) e asciugare accuratamente.
- Non esporre alle intemperie.

GB Read the instructions carefully and keep for future reference

- Check that **Stendipiù** has been opened correctly before use.
- Every so often check that the assembly screws are tightened securely.
- Clean with a damp cloth or with a neutral detergent (not solvents) and dry carefully.
- Do not leave out in bad weather.

F Lire attentivement et conserver en cas de besoin

- Vérifiez le bon déploiement de **Stendipiù** avant de l'utiliser.
- Contrôlez régulièrement que les vis de fixation soient bien bloquées.
- Nettoyer à l'aide d'un chiffon humide ou de détergent neutre (non solvants) et sécher soigneusement.
- Ne pas exposer aux intempéries.

D Aufmerksam lesen und für zukünftige Referenzen aufbewahren

- Überzeugen Sie sich davon, daß **Stendipiù** vollständig geöffnet ist, bevor Sie ihn verwenden.
- Kontrollieren Sie regelmäßig, daß die Montageschrauben immer gut festgezogen sind.
- Mit einem feuchten Tuch oder einem neutralen Reinigungsmittel (keine Lösungsmittel) reinigen und sorgfältig abtrocknen.
- Keinen Witterungseinflüssen aussetzen.

E Leer atentamente y conservar para futuras referencias

- Antes de utilizar **Stendipiù** verificar su perfecta apertura.
- Controlar periódicamente que los tornillos de montaje estén siempre bien bloqueados.
- Limpiar con un paño húmedo o con detergente neutro (no con solventes) y secar cuidadosamente.
- No exponer a la intemperie.

NL Lees deze aanwijzingen met aandacht en bewaar ze voor gebruik later

- Voor gebruik controleren dat **Stendipiù** geheel geopend is.
- Controleer regelmatig dat de montageschroeven altijd goed zijn vastgezet.
- Schoonmaken met een vochtige doek of een neutraal reinigingsmiddel (geen oplosmiddelen) en zorgvuldig droogmaken.
- Niet blootstellen aan weer en wind.

Composizione

Component parts

Composition

Zusammensetzung

Composición

Konstruktie

I • Struttura in legno di faggio.

- Bacchette stendibiancheria in materiale plastico.

GB • Beechwood frame.

- Plastic airing rails.

F • Structure en bois de hêtre.

- Baguettes d'étendage en matière plastique.

D • Gestell aus Buchenholz.

- Stangen des Wäscheständers aus Plastikmaterial.

E • Estructura de madera de haya.

- Varillas del tendadero de material plástico.

NL • Serveerkar van beukehout.

- Waslijnen van kunststof materiaal.

Ricambi

Spare parts

Pièces de rechange

Austauschteile

Repuestos

Onderdelen

Adx cod.0049714710

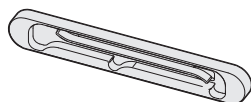

Asx cod.0049714810

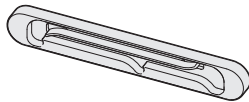

B cod.7010110300



I **Attenzione:** le sostituzioni devono essere richieste solamente tramite il rivenditore.

GB **Note:** spare parts can only be ordered from the retailer.

F **Attention:** les substitutions ne peuvent être effectuées que par l'intermédiaire du revendeur.

D **Wichtig:** ersatz darf nur über den Händler angefordert werden.

E **¡Atención!** las sustituciones deben ser solicitadas solamente a través del revendedor.

NL **Opgelet:** vervangingen dienen uitsluitend via de wederverkooper te worden besteld.

Naturale

03

Noce

06

FOPPAEDRETTI

Via A. Volta, 11 24064 Grumello del Monte, Bergamo - Italy
tel +39 035.830.497 fax +39 035.831.283 www.foppapedretti.it

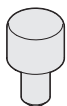

x 4

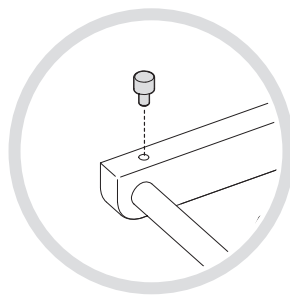
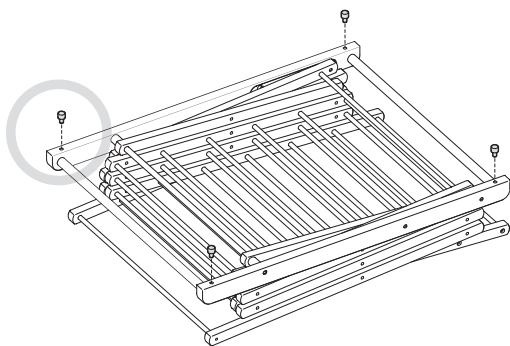

Modo d'uso

open

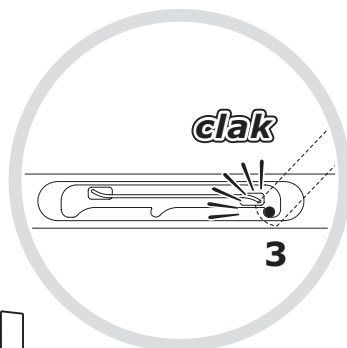
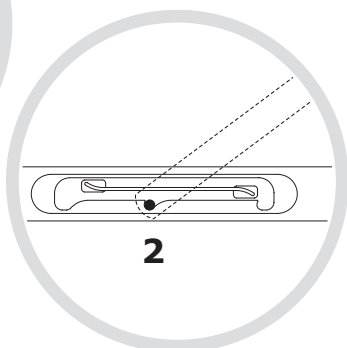
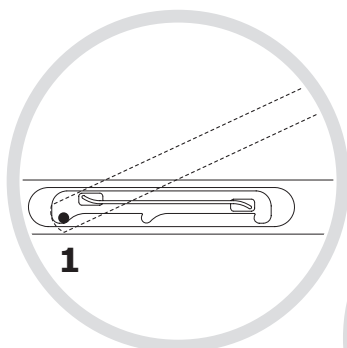
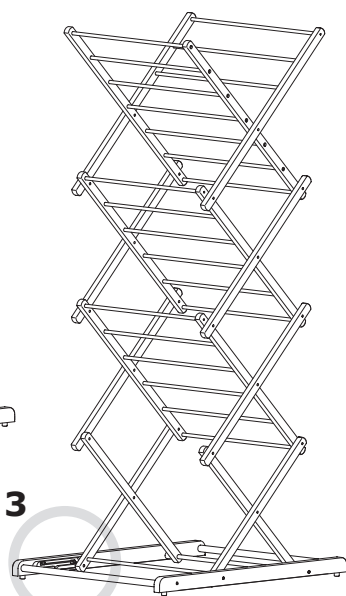
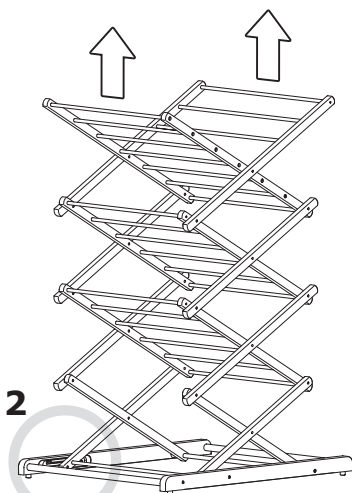
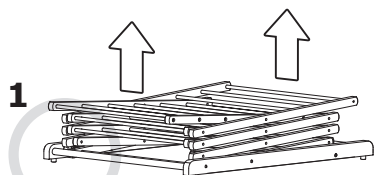

closed

